

SONY®

Video Communication System

PCS-G50

PCS-G50P



Connect Your Vision

IPELA™

Stunning video and audio brought to you by the "IPELA" series of visual communication products that encompass the three-pronged concept of "Reality," "Intelligence," and "Usability." "IPELA" is the identity symbolizing the Sony vision for the workplace of the future, connecting people, places, and information with reality that has never before been achieved. "IPELA" lets you share ideas and dreams as if you are collocated when your counterpart is half-way around the world, experiencing images as if you are actually there.

Reality

- High Quality Video (4CIF Video at 4Mb/s)
- Superb Sound (MPEG-4 AAC)

Intelligence

- Encryption Function (AES)
- Network Quality of Service (ARC, ARQ, FEC)

Usability

- Multi-Point Videoconferencing
- Streaming Function
- Memory Stick Recording

Real audiovisual communication over networks – this is business communication of the future, this is business communication brought to you today, this is "IPELA."

Sony PCS-G50*1 – The Business Tool for Visual Communication

To stay ahead of the pack in today's tough market, businesses require powerful visual communication tools like the PCS-G50. Sony has combined advanced audio and video technologies with useful features to provide a visual communication tool for all businesses. With the PCS-G50, long distance meetings can be held as if all parties were in the same room, saving the time and trouble of traveling to distant locations for a simple meeting. Providing you with a new and powerful means of communication, the PCS-G50 will be a mainstay for your business.

The PCS-G50 boasts a maximum video transfer rate of 4 Mb/s over an IP network, and it provides extremely high resolution video. By adopting the H.263 video codec/4CIF format, the PCS-G50 produces image resolution comparable to that of standard TV broadcasts. It can also switch to the H.264 video codec for higher throughput or revert to previous versions of the ITU-T videoconferencing codecs to maintain compatibility with legacy systems.

As with other PCS Series models, the PCS-G50, with its internal MCU (Multi-Control Unit) capability, supports simultaneous multi-point videoconferences with six (6) endpoints, and a maximum of 10 endpoints when two PCS-G50 units are cascaded. The PCS-G50 bridges mixed calls between an ISDN network and an IP network, and speed matches (by connecting at the endpoint respective speeds) without lowering the performance of the entire system.

*Other key features of the PCS-G50 include a site-name display function and the capability to record audio and video to **Memory Stick™** media. The PCS-G50 also incorporates features such as data sharing, QoS support functions, an encryption function, a streaming function, and digital whiteboard support, which are all useful features for quality of videoconferencing.*

Effective visual communication is vital to move ahead in today's business. With the feature-rich PCS-G50, not only will your visual communication be effective, it will be affordable.

*1 Unless otherwise noted, "PCS-G50" in the following text refers to both the PCS-G50 and PCS-G50P.

FEATURES

High-Quality Video/High-Speed Network Connection

The PCS-G50 provides excellent picture quality over both ISDN (H.320) and IP (H.323) networks and fully supports the latest non-proprietary ITU-T H.264 video codec standard for maximum customer confidence and flexibility. When video encoding is in accordance with the H.263 protocol, the PCS-G50 supports the 4CIF format at a maximum frame rate of 30 fps, and when in H.264 protocol, it supports the interlaced SIF format at 60 fields per second.^{*2} In addition, the PCS-G50 can achieve a maximum bandwidth of 4 Mb/s with an IP connection, and up to 2 Mb/s with an ISDN connection using an optional PCSA-PRI ISDN unit. This combination of high-quality codec and high-speed network support provides video quality comparable to standard TV broadcasts.

^{*2} The PCS-G50P supports a maximum of 50 fields per second in interlaced SIF format.

Multi-Point Videoconferencing at up to 10 Sites *Fig 1*

Using optional MCU software, the PCS-G50 can be configured to communicate with up to 5 remote videoconferencing sites (6 sites total) simultaneously using either an IP (H.323 protocol) or ISDN (H.320 protocol) connection. It can also support videoconferences in which the connections are a combination of IP and ISDN using a bridging function. And because the PCS-G50 has a "speedmatching" function, it maximizes performance by not reducing the higher speed connection to match the lower speed connection, as is done with some videoconferencing systems. Moreover, two PCS-G50 units - each installed with the optional MCU (H.323) software - can be cascaded with an IP connection to support a maximum of 10 simultaneous sites. What is unique about the PCS-G50 is that it provides high quality, H.264 CIF video and clear MPEG-4 AAC audio, even in a multi-point videoconference. And of course, the PCS-G50 allows users to expand from a peer-to-peer videoconference to a multi-point videoconference by simply dialing up new connections.^{*3}

^{*3} When adding a new endpoint on the same network (IP or ISDN), the system will default to the lowest resolution video standard of all endpoints.^{*3}

Site-Name Display *Fig 2*

During multi-point videoconferences, it can be difficult to keep track of all of the participants; however, with the PCS-G50 site-name display function, this is no longer the case. The PCS-G50 can display anything from company or branch names to geographical locations on a monitor, allowing videoconference participants to keep track of all parties.

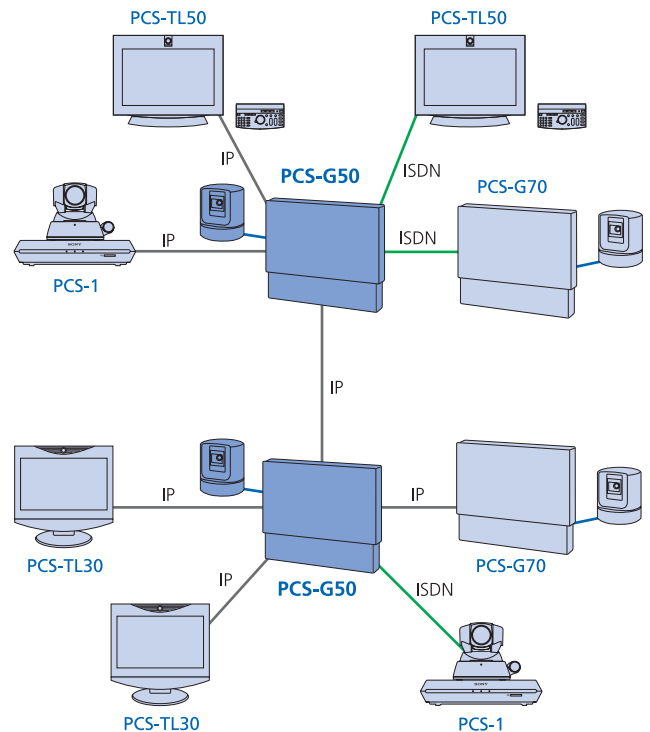

Fig 1 Multi-Point Videoconferencing at up to 10 Sites



Fig 2 Site-Name Display

Flexible Display Patterns at all Sites

In addition to conventional patterns of display – such as showing the far-end site on a full screen or displaying near-end and far-end sites in picture-in-picture mode – a variety of other display patterns are available with the PCS-G50. Supporting both 4-screen and 6-screen continuous-presence modes, the PCS-G50 can display the most appropriate pattern to match the number of sites that are connected. In both full-screen and continuous-presence modes, the following two display options are available:

Voice Switching *Fig 3*

The PCS-G50 defaults to voice switching, which displays the far-end site that is actively talking on the monitor when the unit is in full-screen mode. In continuous-presence mode, the site that is actively speaking is displayed on the largest of the six sub screens, and the near-end site is displayed on the sub screen where the original far-end site was.

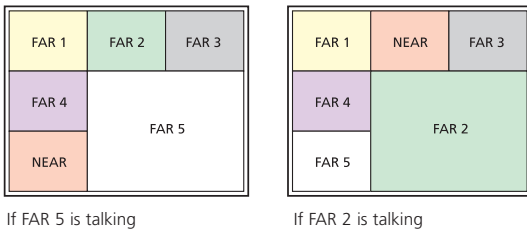

Fig 3 Voice Switching in Continuous Presence Mode

Fixed Site

As its name suggests, the selected far-end site is continuously displayed on the monitor when the unit is in full-screen mode. In continuous-presence mode the selected far-end site is displayed in the largest of the six sub screens, and the other sites are fixed as well.

Audiovisual (A/V) Recording to Memory Stick™ Media

Capturing audio and video during a videoconference is important to keep a record of what was conveyed during a conference. With the PCS-G50, audio and video displayed on the main monitor can be recorded^{*4} directly to **Memory Stick™** media in MPEG-4 format and can be played back on any PC using QuickTime® media player.

^{*4} AV recording is not supported when AES is active. Also, presentation data cannot be recorded.

Data-Sharing Capabilities/Digital Whiteboard Support

Data originated on your PC can be shared with your videoconferencing counterparts, making communication even more effective. Any image that can be displayed on a PC can be sent or received^{*5} in native XGA resolution, allowing all parties to share data during a videoconference. In addition, information drawn up on a digital whiteboard^{*6} can also be viewed in real time by all parties participating in a videoconference or captured and stored for later reference.

^{*5} Sending data requires the optional PCSA-DSB1S Data Solution Box (DSB); however, the DSB is not required for receiving data

^{*6} Please contact your local Sony sales office for information on compatible digital whiteboards.

Built-in Streaming Function *Fig 4*

To broadcast^{*7} your videoconferences to a large audience, for example, with educational lectures or live corporate speeches, the PCS-G50 features a built-in streaming function that allows remote users to log on from any PC using an Internet browser.^{*8} Simply enter the URL provided by the PCS-G50 administrator into your Internet browser, and you can have instant access to the active audio and video from the PCS-G50. With this useful feature, hundreds of people with access privileges can view and listen to your videoconference session from almost any location that has access to a network.

^{*7} The system must be configured with a multicast router.

^{*8} Recommended system requirements: Microsoft Windows XP, Microsoft Internet Explorer 6.0 or higher, and QuickTime 6.0 or higher.

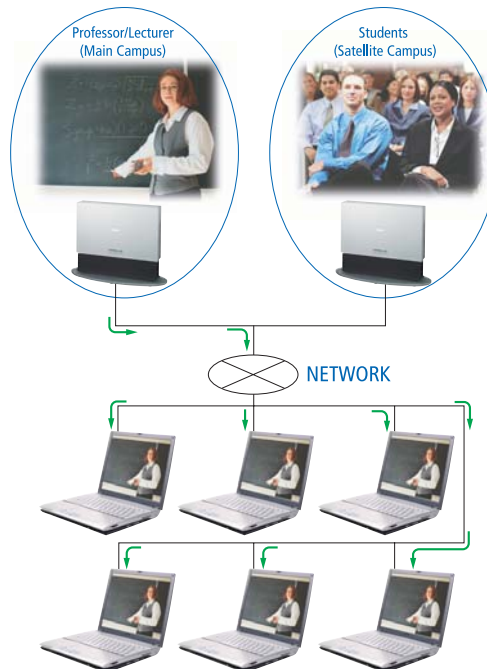

Fig 4 Built-in Streaming Function

Superb Sound *Fig 5*

The PCS-G50 reproduces clear and natural-sounding audio using MPEG-4 AAC (Advanced Audio Coding) at 14 kHz. And a built-in echo cancellation system minimizes unwanted echoes during a videoconference.

The PCS-G50 is also compatible with a number of Sony external microphones and speakers, including unidirectional and omnidirectional models. Professional A/V integrators will particularly appreciate the power and flexibility of this system to be customized for best application match.

For exceptional sound quality in rooms with conference tables in a U-shape or in a classroom layout, the optional unidirectional PCSA-A7 microphone is ideal. Up to 40 units can be daisy chained to ensure that all participants sitting near a microphone can be heard.

PCSA-A7 (U-Shaped Conference Table)

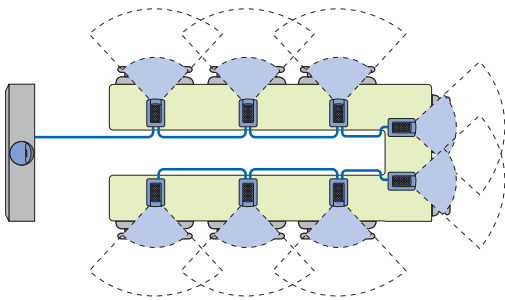

PCSA-A7 (Classroom Layout)

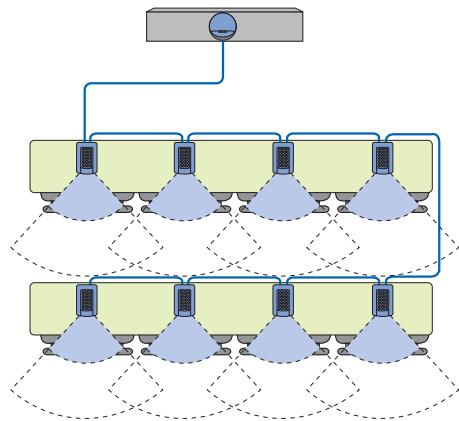

Fig 5 Superb Sound

Easy-to-Use Remote Commander™ Unit/Intuitive GUI *Fig 6*

The PCS-G50 has a number of features that make it easy to operate. The cursor keys on the Remote Commander unit can be used to select and call any one of three contacts, which are pre-programmed and displayed in the Launcher Menu. Up to 500 contacts can be stored in the PCS-G50 common phone book for quick and easy dialing. In addition, the unit supports a call history log, which stores the last 32 incoming and outgoing calls so that the user can readily select and dial a recent contact.



Launcher Menu

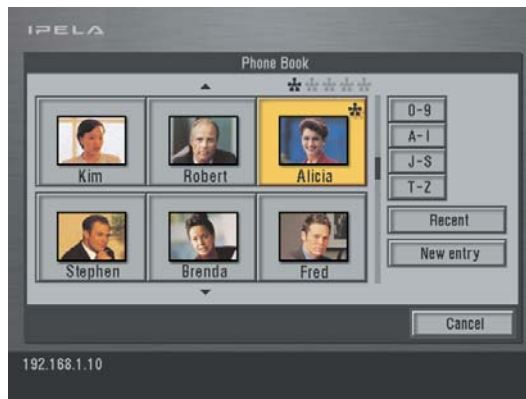

Phone Book

Fig 6 Graphical User Interface

Stylish Design

With its elegant design and optional stands for both the camera unit and the codec unit, the PCS-G50 can fit into even the classiest of conference rooms. In addition, if you wish to place the camera above a 30" to 50" PDP/LCD TV or monitor, a convenient optional camera/codec stand, the PCSA-STG50, is available. This stand neatly houses the codec so that it is behind the TV or monitor and allows the camera to be placed above for more natural eye contact during videoconferences.

Memory Stick Support^{*9}

Private phone books can be created and stored on **Memory Stick** media. By simply inserting the **Memory Stick** media into the PCS-G50, the unit automatically recognizes and activates the private phone book, thereby eliminating the need to re-enter contact information to place a call. **Memory Stick** media has a number of other uses, such as storing captured images, PC-generated data, and digital whiteboard drawings. The media can also be used for installing and updating software.

^{*9} In addition to **Memory Stick**, **Memory Stick PRO™** and **Memory Stick DUO™** with an adaptor can be used.

Secure Videoconferencing – Advanced Encryption Standard (AES)

Secure videoconferencing over a network is possible because the PCS-G50 supports AES 128-bit encryption. The PCS-G50 offers two encryption modes with an IP connection, one that complies with the ITU-T H.235 standard, which allows encrypted communication with other H.235 compliant systems, and another that is Sony proprietary, which is ideal when connecting to other PCS Series systems and offers higher security. When either of these encryption modes is active, video, audio, and graphics are encrypted for the duration of the videoconference.

QoS (Quality of Service) Enhancement Functions

When holding a videoconference over a network, a common concern is how to maintain video and audio quality when the performance of the network is changing. The PCS-G50 provides three advanced functions^{*10} to enhance QoS over a network:

Adaptive Rate Control (ARC)

The adaptive rate control function automatically varies the video data transfer rate to meet changing network conditions. It also selects the most appropriate frame rates, which helps prevent video breakup.

Real-time Auto Repeat Request (ARQ)

The real-time ARQ function recovers lost IP packets. This is achieved by buffering the packets at the encoder and resending any that are lost. This feature helps maintain audio and video quality, and helps prevent picture collapse even under high network traffic conditions.

Forward Error Correction (FEC)

The PCS-G50 employs an FEC function that corrects errors in transmission at the receiving end. If a transmission error occurs, the PCS-G50 can repair the data and accurately reproduce the original video signal.

^{*10} When hybrid mode is selected, the best balance between these QoS functions is automatically set to match network conditions.



PCS-G50 Codec Unit Rear Panel

SAMPLE SYSTEM CONFIGURATION

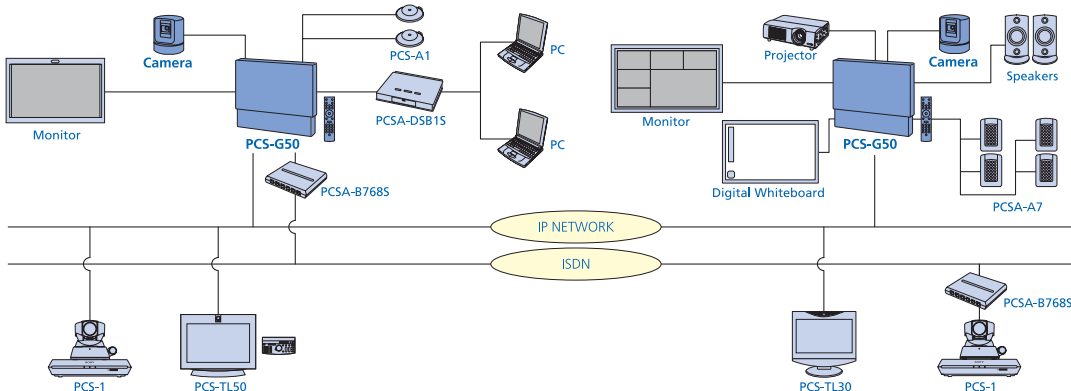

OPTIONAL ACCESSORIES



PCSA-DSB15
Data Solution Box



PCSA-PRI
ISDN Unit



PCSA-B768S
ISDN Unit (6 BRI)



PCSA-B384S
ISDN Unit (3 BRI)



PCSA-M0G50
H.320 MCU Software
PCSA-M3G50
H.323 MCU Software



PCSA-SP1
SIP Software



PCSA-A7P4
Echo-cancelling Microphone
(4 mics per package)



PCS-A1
Omnidirectional Microphone



PCSA-A3
Unidirectional Microphone



EVI-D70/EVI-D70P
Communication Video Camera (white)



EVI-D70/EVI-D70P
Communication Video Camera (black)



EVI-D100/EVI-D100P
Communication Video Camera



PCSA-STMG70
Codec Stand



PCSA-STCG70
Camera Stand



PCSA-STG50
Camera Stand

RECOMMENDED DATA PROJECTORS



VPL-CX76
2500 ANSI Lumens
XGA (1024 x 768 Resolution)



VPL-CX86
3000 ANSI Lumens
XGA (1024 x 768 Resolution)



VPL-PX41
3500 ANSI Lumens
XGA (1024 x 768 Resolution)

SPECIFICATIONS

Video	
Signal system	PCS-G50: NTSC PCS-G50P: PAL
Standards	H.261 (Annex D), H.263 (Annex D,F), H.263+ (Annex J), H.263++ (Annex U,W), H.264, MPEG-4 SP@L3, H.239 Video and Presentation Data Support*
Resolution	SQCIF (128 x 96, reception only), QCIF (176 x 144), CIF (352 x 288), 4CIF (704 x 576, H.263 only), Interlaced SIF (H.263, H.264 only)
Frame rate	Max. 30 frames/s (H.261, H.263, H.263+, H.263++, H.264, and MPEG-4 SP@L3) Interlaced SIF Mode (PCS-G50: 60 fields/s, PCS-G50P: 50 fields/s)
Bit rate	Up to 4 Mb/s in H.323 (Incl. audio)** Up to 2 Mb/s in H.320 (Incl. audio) when configured with the PCSA-PRI Up to 768 Kb/s in H.320 (Incl. audio) when configured with the PCSA-B768S Up to 384 Kb/s in H.320 (Incl. audio) when configured with the PCSA-B384S
Audio	
Bandwidth and coding	G.711: 3.4 kHz at 56/64 Kb/s G.722: 7.0 kHz at 48/56/64 Kb/s G.722.1: 7.0 kHz at 24/32 Kb/s (H.323) G.728: 3.4 kHz at 16 Kb/s G.723.1: 3.4 kHz at 5.3/6.3 Kb/s (H.323) G.729: 3.4 kHz at 8 Kb/s (H.323) MPEG-4 AAC (mono) 14 kHz at 64/96 Kb/s (H.323) at 48 Kb/s (H.320)
Echo cancellation	Noise Suppressor included, Automatic Gain Control included
Graphics	
XGA	1024 pixels x 768 lines (H.263), with PCSA-DSB1S
4CIF	704 pixels x 576 lines (H.261 Annex D and H.263)
Picture in Picture	
Sub screen size	4.3" (256 x 192), One of four corners
ITU-T Standards (excludes audio/video standards)	
	H.320, H.323 H.221 Bonding H.281 FECC H.225.0 H.242 H.243 H.245 T.120
Network Protocols	
	TELNET (Server), HTTP (Server), FTP (Server), SNMP (Agent), DNS (Client), DHCP (Client), RTP/RTCP, TCP/UDP, ARP, SIP
Multipoint Capabilities	
	Up to 6 sites (H.320/H.323)*** Up to 10 sites (H.320/H.323)****
Lip Synchronization	
	Manual On/Off
Security	
	H.233, H.234, H.235 Sony Proprietary AES Encryption, Password Protection
Network Features	
QoS (Quality of Service)	ARC (Adaptive Rate Control), Real-time ARQ (Auto Repeat reQuest), IP Precedence, DiffServ
NAT	Network Address Translation
UPnP	Universal Plug and Play
Camera Unit	
Image device	1/4 type CCD
Horizontal resolution	NTSC: 470 TV lines, PAL: 460 TV lines
Focal length	3.1 to 31 mm (F1.8 to 2.9)
Focus	Auto/Manual
IRIS	Auto
Zoom ratio	x10 Optical zoom (x40 with digital zoom)
Pan angle	-100° to +100° (Max. 300°/sec)
Tilt angle	-25° to +25° (Max. 125°/sec)
Preset	Up to 6 positions
S/N	More than 50 dB
Others	Back light compensation, Auto white balance

Remote Commander	
Format	Wireless SIRCS
Interfaces (Communication Terminal)	
Video	D-Sub 15-pin Dedicated Camera I/F x1 S-video or Composite input x1 (switchable with conversion connector) S-video output x2 (for main/sub monitor) Composite output (AUX) RGB output
Audio	Line input RCA AUX input RCA (bypasses echo cancellor) External analog microphone input, Mini-jack (Plug in power) x2 External digital microphone input x2 Line output RCA x2 (one mixed output)
Network	10Base-T/100Base-TX External ISDN Unit I/F
Control	SIRCS IR Out x2 Wired SIRCS In (Control-S) RS-232C
DSB I/F	Dedicated D-Sub 15
RGB I/F	RGB output
Memory Stick	Memory Stick slot
Digital whiteboard	Dedicated connector
Interfaces (Camera Unit)	
Video	IR for DS150
Terminal	Dedicated 23-pin
AUX camera	8-pin Mini-DIN
General	
Operating temperature	5 °C to 35 °C
Operating humidity	30% to 70%
Storage temperature	-20 °C to +55 °C
Storage humidity	25% to 75%
Power Requirements	PCS-G50: AC 120 V, 50/60 Hz, PCS-G50P: AC 220 V to 240 V, 50/60 Hz
Power Consumption	DC 19.5 V, 5 A
Communication Terminal	420 x 66 x 254 mm (16 5/8 x 2 5/8 x 10 inches), excl. projections
Dimensions (W x H x D)	
Camera Unit	131 x 141 x 130 mm (5 1/4 x 5 5/8 x 5 1/8 inches), excl. projections
Dimensions (W x H x D)	
Remote Commander	47 x 43 x 195 mm (1 7/8 x 1 3/4 x 7 3/4 inches), excl. projections
Dimensions (W x H x D)	
Communication Terminal	4.6 kg (10 lbs 2 oz)
Mass	
Camera Unit	1.0 kg (2 lbs 3 oz)
Mass	
Remote Commander	180 g (6.3 oz), incl. batteries
Mass	
System Components and Supplied Accessories	
Communication Terminal	
Camera Unit (includes dedicated 3 m camera cable)	
Remote Commander	
AC Adaptor/Power Cord	
Omnidirectional Microphone	
IR Repeater x2	
Manganese Battery for Remote Commander x2	
Operation Manual CD-ROM (Japanese, English, French, Spanish, Italian, German, Portuguese, Simplified Chinese)	
Operation Guide	
Quick Connection Guide	
Cable Connection Guide	
Worldwide Warranty Booklet	
Audio Cable (1.0 m)	
S-Video Cable (1.5 m)	
Mini DIN 7-pin to RCA Conversion Connector	

* The optional PCSA-DSB1S Data Solution Box is required to send presentation data.

** When the H.261 video standard is used, up to 2 Mb/s is supported.

*** Requires optional MCU software. IP/ISDN Bridging is possible.

**** Requires optional MCU software. Connections between base units must be IP (H.323). IP/ISDN Bridging is possible.

Distributed by

©2005 Sony Corporation. All rights reserved.

Reproduction in whole or in part without written permission is prohibited. Features and specifications are subject to change without notice.

All non-metric weights and measurements are approximate.

Sony, IPELA, Remote Commander, **Memory Stick**, **Memory Stick PRO**, **Memory Stick Duo**, and the **Memory Stick** logo are trademarks of Sony Corporation.

Some images in this brochure are simulated.

All other trademarks are the property of their respective owners.