

Specifications

	TK-C215V12E	TK-C215V4E	TK-C210FWE
Camera			
Signal system	PAL	PAL	PAL
Image device	1/4" IT CCD	1/4" IT CCD	1/4" IT CCD
Number of effective pixels	440,000	440,000	440,000
Pick-up area	3.6 mm (H) × 2.7 mm (V)	3.6 mm (H) × 2.7 mm (V)	3.6 mm (H) × 2.7 mm (V)
Scanning system	15.625 kHz (H), 50 Hz (V)	15.625 kHz (H), 50 Hz (V)	15.625 kHz (H), 50 Hz (V)
Sync system	Internal, Line lock	Internal, Line lock	Internal only
Video output	Composite video signal: 1.0 V (p-p), 75 ohms (BNC)	Composite video signal: 1.0 V (p-p), 75 ohms (BNC)	Composite video signal: 1.0 V (p-p), 75 ohms (BNC)
Horizontal resolution (typ.)	540 TV lines	540 TV lines	500 TV lines
Video S/N ratio	50 dB	50 dB	48 dB
Minimum illumination (typ.)	8.3 lx F1.6, AGC on, 50 % 2.9 lx F1.6, AGC on, 25 % 4.2 lx F1.6, AGC on, 50 % (optional clear cover) 1.3 lx F1.6, AGC on, 25 % (optional clear cover)	5.6 lx F1.3, AGC on, 50 % 2.1 lx F1.3, AGC on, 25 % 2.9 lx F1.3, AGC on, 50 % (optional clear cover) 0.9 lx F1.3, AGC on, 25 % (optional clear cover)	7.5 lx F2.0, AGC on, 50 % 2.7 lx F2.0, AGC on, 25 % 3.6 lx F2.0, AGC on, 50 % (optional clear cover) 1.3 lx F2.0, AGC on, 25 % (optional clear cover)
Colour mode			
B&W mode	4.9 lx F1.6, AGC on, 50 % 1.6 lx F1.6, AGC on, 25 % 2.4 lx F1.6, AGC on, 50 % (optional clear cover) 0.8 lx F1.6, AGC on, 25 % (optional clear cover)	3.6 lx F1.3, AGC on, 50 % 1.3 lx F1.3, AGC on, 25 % 1.7 lx F1.3, AGC on, 50 % (optional clear cover) 0.6 lx F1.3, AGC on, 25 % (optional clear cover)	
AGC	Yes (on/off)	Yes (on/off)	Yes
Backlight compensation	on (1pattern)/off	on (1pattern)/off	on (1pattern)/off
White balance	ATW/Manual	ATW/Manual	ATW only
Easy day/night	Yes	Yes	—
Focus adjust	Yes	Yes	—
LENS			
Focal length	f = 3.8 mm to 45.6 mm, 12x vari-focal	f = 2.8 mm to 10 mm, 3.6x vari-focal	f = 2.9mm, fixed
Max aperture ratio	F1.6 to F2.7	F1.3 to F3.0	F2.0
Iris	DC iris	DC iris	Fixed, AES only
Angle of vision	52° (H) × 39° (V) to 4.5° (H) × 3.4° (V)	73° (H) × 54° (V) to 20° (H) × 15° (V)	71° (H) × 53° (V)
Angle adjustment range (Horizontal/Vertical/Rotation)	350°/±80°/±175°	350°/±80°/±175°	350°/±80°/±175°
GENERAL			
Power supply	AC 24V (50Hz/60Hz), DC 12V	AC 24 V (50Hz/60Hz), DC 12 V	AC 24 V (50Hz/60Hz), DC 12 V
Power consumption	550 mA	340 mA	220 mA
Operating temperature	-10 °C to 50 °C	-10 °C to 50 °C	-10 °C to 50 °C
< Recommended >	< 0 °C to 40 °C >	< 0 °C to 40 °C >	< 0 °C to 40 °C >
Dimensions	ø145 mm × 120 mm (H)	ø145 mm × 120 mm (H)	ø145 mm × 120 mm (H)
Weight	530 g	470 g	450 g

Controls, connectors and indicators

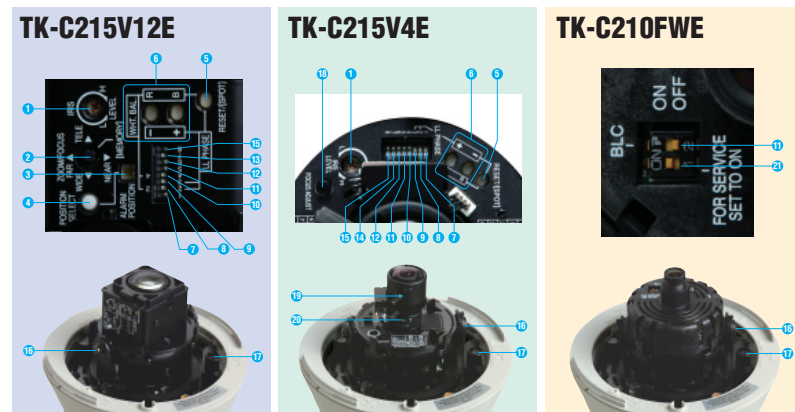

- ① [IRIS LEVEL] Iris level adjustment ② [ZOOM/FOCUS, MEMORY] Zoom/Focus adjustment switches, position memory button
 ③ [ALARM POSITION] Status indication LED ④ [POSITION SELECT] Position select button ⑤ [RESET/SPOT] Reset/Spot button
 ⑥ [R/B, +/-] R/B, +/- adjustment button ⑦ [AGC] Auto gain control switch ⑧ [SELECT] WHT.BAL./PHASE setting switch
 ⑨ [SYNC] Synchronization system selection switch ⑩ [WHT.BAL.] ATW/Manual selection switch ⑪ [BLC] Backlight compensation switch ⑫ [DAY/NIGHT] Easy day/night switch ⑬ [ALARM] Alarm input mode selection switch ⑭ [RESERVED] Not used (set to off) ⑮ [RESET/SPOT] Reset/Spot correction selection switch ⑯ Tilt lock screw ⑰ Horizontal lock screw ⑱ [FOCUS ADJ.] Focus adjustment switch ⑲ Focus adjustment ring ⑳ Zoom adjustment ring ㉑ Service switch (set to on)

Dimensions

Unit: mm

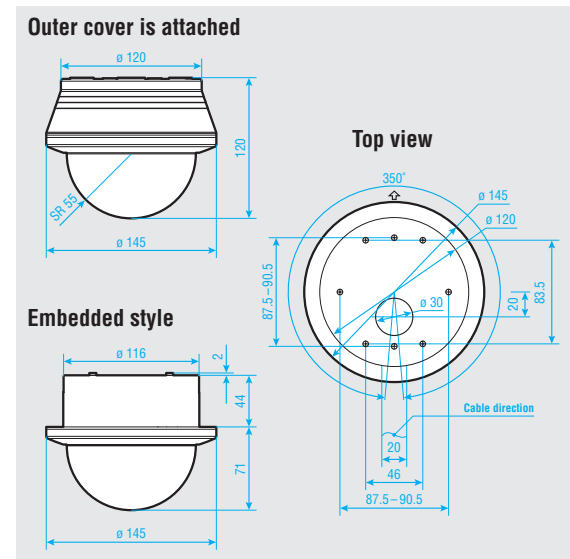

Design and specifications subject to change without notice.



■ Hachioji Business Centre of Victor Company of Japan, Ltd. has received ISO14001 Certification for environmental management and ISO9001 Certification for quality assurance management.

JVC®

The Perfect Experience

540 TV Lines

FIXED COLOUR DOME CAMERA

TK-C215 series

TK-C215V12E 12x variable focal lens

TK-C215V4E 4x variable focal lens

TK-C210FWE Fixed wide angle lens



- 1/4" IT CCD with 440,000 effective pixels
- 540 TV lines of horizontal resolution (TK-C215V12E/TK-C215V4E)
- 500 TV lines of horizontal resolution (TK-C210FWE)
- Super LoLux™ sensitivity
TK-C215V12E: 1.3 lx (colour), 0.8 lx (B&W)
TK-C215V4E: 0.9 lx (colour), 0.6 lx (B&W)
TK-C210FWE: 1.3 lx (colour)
- Easy day/night function (TK-C215V12E/TK-C215V4E)
- Alarm zoom function (TK-C215V12E)
- Pendant and wall mount available (with optional brackets)

- Triple axis rotation system for wide lens adjustment:
horizontal: 350°, vertical: ±80°, rotation: ±175°
- Full featured security camera
 - Easy focus adjustment
 - Monitor video output (RCA)
 - Automatic gain control on/off (max.26 dB)
 - Auto tracking white balance (ATW) and manual modes 2,300K to 10,000K (TK-C215V12E/TK-C215V4E) 2,900K to 8,000K (TK-C210FWE)
 - Backlight compensation on/off
 - Sync systems INT/Line lock (TK-C215V12E/TK-C215V4E)
 - AC 24V/DC 12V power supply

JVC®

DISTRIBUTED BY

Printed in Japan
KCN-1839 CETKC215YT0511

JVC is the trademark or registered trademark of Victor Company of Japan Limited.

JVC's new high-performance dome camera is capable of inconspicuously carrying out surveillance at airports, stores, factories and building exits/entrances. Equipped with JVC's latest technology, this all-in-one camera solution provides outstanding image performance with 540 TV lines of horizontal resolution, as well as employs a new easy-to-install mechanism for plug and play setup. As a full-spec camera, the TK-C215 series dome camera comes with a complete array of high-performance features.

540 resolution: The highest in the industry

The TK-C215 series comes with a 1/4" Interline Transfer CCD with 440,000 effective pixels for accurate colour reproduction and signal-to-noise ratio of 50 dB (AGC off). This outstanding image performance provides users with a new realm of surveillance. TK-C210FWE features 500 TV lines of horizontal resolution and signal-to-ratio of 48dB (max).



Simple and flexible installation

The TK-C215 series uses an unprecedented flush mount installation method with which installation is as simple as ninety-degree rotation of the three L-shaped mounting brackets stored in the dome camera to secure it in place. No extra brackets are required. With this new method, installation can be completed in nearly one-fifth the time of our conventional surveillance cameras. Moreover, surface mounting is possible, too.

Easy flush mount

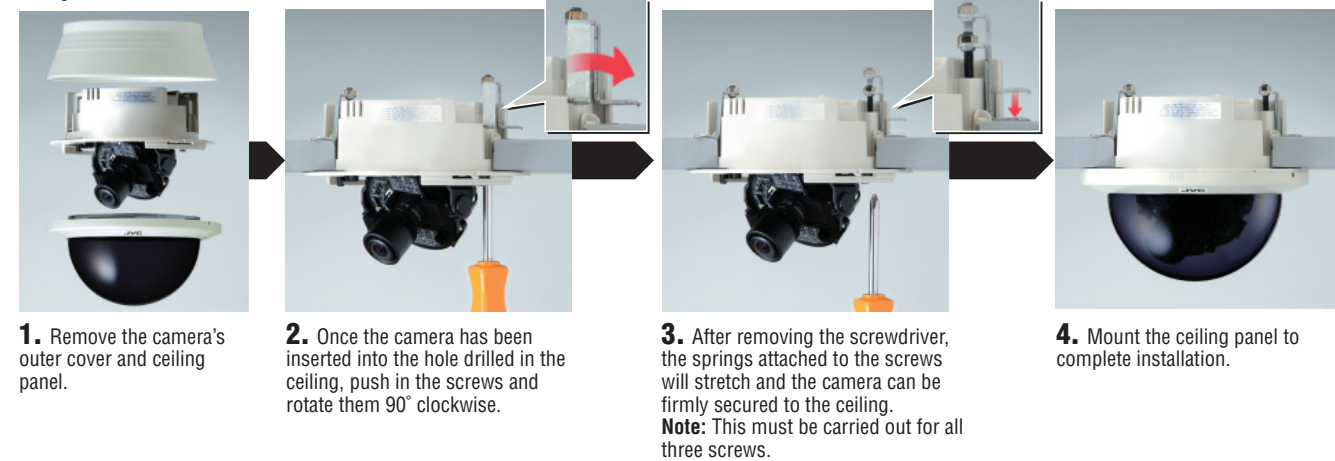

Flexibility of installation location

Extra mounting brackets are unnecessary when mounting the TK-C215 series to a ceiling, and installation is possible even for diagonal ceilings and walls thanks to the camera's wide lens angle adjustment mechanism.



Optional Brackets



Choose from the following three models to meet your specific needs

TK-C215V12E

- High resolution 540 TV lines
- Vari-lens 12 times

TELE angle: This is a digitally magnified sample image at the tele-angle position. The 12x optical zoom lens will actually provide clear and crisp image in 540 TV lines.

WIDE angle

TK-C215V4E

- High resolution 540 TV lines
- Vari-lens 4 times

TELE angle

WIDE angle

TK-C210FWE

- High resolution 500 TV lines
- Fixed lens
- Wide angle

WIDE angle

Easy day/night function

TK-C215V12E and TK-C215V4E automatically use colour mode when the object is bright, and B&W mode when it is very dark. In B&W mode, AGC remains active to ensure high performance even under low-light conditions. Easy day/night function assures around-the-clock optimum imaging performance.

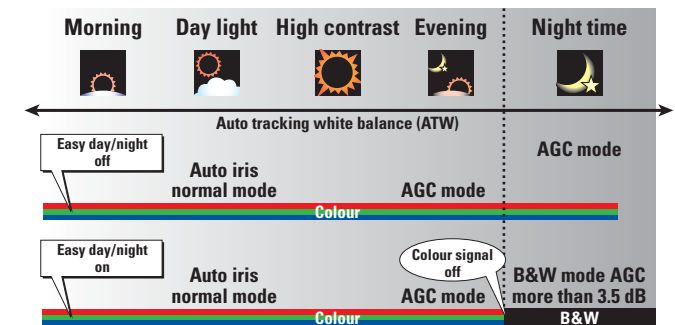

Alarm zoom function (TK-C215V12E only)

The TK-C215V12E comes with a 12x lens, alarm input interface, and memory for two different lens positions. Thanks to the memory function, the camera lens unit can be set for two lens positions, and the zoom-up mechanism moves to its alarm position from its regular position when alarm signal is received. When an object enters the range of surveillance, the camera engages with the sensor installed at the door or exit/entrance, an alarm signal is activated and the camera automatically optical zooms in on the object. Then, once the object has left the surveillance range, the camera zooms out to the original scene.

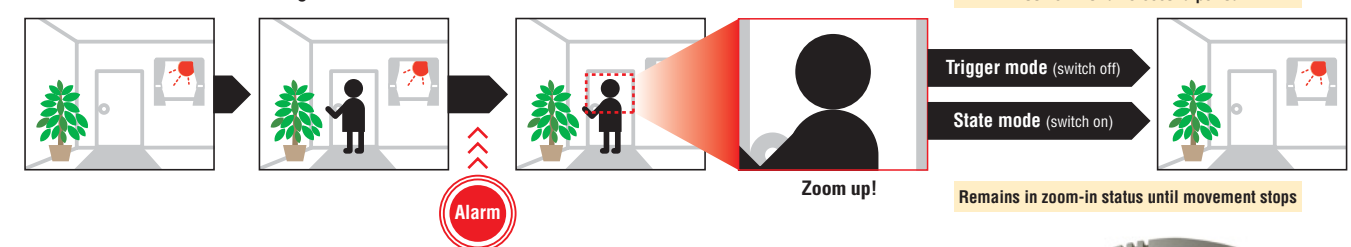

Triple axis rotation system for wide lens adjustment

The TK-C215 series's lens angle can be freely adjusted within the following range: 350°(horizontal), ± 80°(vertical) and ± 175°(rotation). Since images do not appear inverted even when the lens angle is set at a rotation of ± 175°, the camera can be installed virtually anywhere. Thanks to this outstanding lens angle adjustment mechanism, surveillance image quality will not be compromised regardless of where the dome camera is installed.

