

TPS-15G-QM

Isys® G-Series 15" Tilt Touchpanel w/QuickMedia® Transport Technology

Crestron's Isys G-Series touchpanels deliver a higher level of performance with dual-window video, RGB, and HDTV display to meet the demands of today's sophisticated control and automation applications. Incorporating modern styling in a versatile tiltcase design, the Isys TPS-15G-QM features a spectacular 15" XGA display offering a wide viewing angle with exceptional brightness and contrast for stunning control graphics, high-resolution images, and full-motion HD video.

Crestron touchpanels offer an ideal user-interface for multimedia presentation, videoconferencing, home automation, and much more, providing a wide-open canvas for the creation of custom control screens tailored to the needs of the end-user. Touchpanels do away with piles of remote controls, cryptic control panels and cluttered wall switches, simultaneously expanding and simplifying control over a broad range of complex devices and systems.

Isys®

Isys power and beauty are infused throughout Crestron's entire touchpanel lineup. Under the hood, the TPS-15G-QM offers vibrant 24-bit color depth with 8-bit alpha channel transparency to produce incredible 3D graphics using DNav dynamic menu objects, dynamic graphics and text, animations, multimode objects, and PNG translucency - all with astonishing speed.

Synapse™

Crestron's exclusive Synapse Image Rendering Algorithm enables system programmers to produce amazing graphics - faster and easier. Advanced antialiasing delivers crisper, sharper objects and text. Enhanced 3D effects add new depth and style. And because Synapse is native to the touchpanel, memory requirements and upload time are substantially reduced.

Windows® SideShow™ Enabled

New support for Windows® SideShow™ gives the TPS-15G-QM access to all kinds of PC and Web-based content such as news feeds, sports scores, stock tickers, weather alerts, media guides, email messages, and appointment notifications all through a simple network connection to a Windows Vista™ computer.

Dual-Window HD Video and RGB*

The TPS-15G-QM can simultaneously display two fully-scalable, full-motion video windows, each supporting standard video, HDTV, and high-resolution RGB signals from external AV and computer sources. Discrete video scalers with motion adaptive deinterlacing bring out the highest detail, minimizing visible scan lines and motion artifacts for a truly remarkable picture. Advanced gamma correction and built-in time base correction ensure accurate color reproduction and a jitter-free image.

Touch-the-PC

Crestron's exclusive "Touch-the-PC" technology allows real-time touchpanel navigation of any Windows PC through a direct high-speed serial connection.

Interactive Annotation

Built-in annotation capability allows presenters to write or draw over live computer and video images right on the touchscreen using a finger, stylus, or mouse. Moving images can also be frozen onscreen to allow annotation over a still picture. Brush sizes and colors are selectable on the fly. Remote annotation capability allows multiple touchpanel users to draw over the same image, supporting interactive annotation between several participants in a courtroom, classroom, or similar environment. The image can also be output to a video display for live audience presentation.



High-Quality Audio*

The high-powered biamplified speaker system provides amplification for external AV sources, and supports intercom functionality in combination with the integrated microphone. Customized WAV files can be loaded on the touchpanel to add dimension to the touchscreen graphics with personalized sounds, button feedback, and voice prompts.

QuickMedia®

All audio and video connections are facilitated using Crestron's revolutionary QuickMedia transport, providing a flexible yet remarkably simple wiring solution. Through QuickMedia (QM), the TPS-15G-QM interfaces directly with other QM-based products using inexpensive CAT5e type cable.

The two QM Input ports each support non-interlaced RGB up to 1600 X 1200 pixels, as well as composite, S-Video, and component video signals. QM Input #1 includes software-adjustable compensation for cable runs up to 450 feet; Input #2 allows up to 450 feet for video, 300 feet for HDTV, and shorter distances for RGB computer signals. Both QM Inputs receive audio signals from external microphone and stereo line level sources.

The QM Output port allows RGB output of the touchpanel screen image to feed a display device for audience presentation. A 24-bit digital audio signal is also present for distribution of the internal microphone signal.

High-Speed Connectivity

Both Cresnet and high-speed Ethernet are standard on the TPS-15G-QM, providing for easy network integration and seamless communications with Crestron control systems. USB connectivity is also included for connection of an external mouse, touchscreen, or similar pointing device†.

Functional Tiltcase Design

The stylish tiltcase housing allows smooth tilt adjustment from 45 to 90 degrees, and features an integral cable strain relief system and rear cover to secure and hide the connections at the back of the touchpanel. Five backlit pushbuttons are also provided, allowing for quick access to commonly used functions.

> 15" active matrix touchscreen display

TPS-15G-QM

- > 24-Bit Isys graphics | 1024 x 768 resolution
- > Synapse image rendering algorithm
- > Windows SideShow-enabled
- > DNav dynamic menu objects
- > Dual-window full-motion video, HDTV and RGB display*
- > Interactive annotation capability
- > Built-in biamplified speaker system and microphone*
- > QuickMedia AV connectivity | audience presentation output*
- > High-speed Ethernet and Cresnet communications
- > Tiltcase housing with integral rear cover and cable strain relief
- > Backlit "hard key" pushbuttons

SPECIFICATIONS

Touchscreen Display

Display Type: TFT Active matrix color LCD
Size: 15 inch (38.1 cm) diagonal
Aspect Ratio: 4:3 XGA
Resolution: 1024 x 768 pixels
Brightness: 350 nits (cd/m²)
Contrast: 700:1
Color Depth: 24-bit, 16.7M colors
Illumination: Backlit fluorescent
Viewing Angle: ±85° horizontal, ±85° vertical
Touchscreen: Resistive membrane

Processor

CPU: 32-bit Freescale ColdFire® Microprocessor

Memory

DDR RAM: 128 MB
Flash: 64 MB
Compact Flash: Accepts up to 4GB Type II CF (not included)
Maximum Project Size: 160 MB

Graphic Engine

Isys engine, 24-bit non-palette graphics + 8-bit alpha channel transparency, 16.7 million colors, Synapse image rendering algorithm, multi-mode objects, DNav dynamic menu objects, dynamic graphics, Windows® SideShow™ enabled, PNG translucency, full-motion (60 fps) animation, transition effects, color key video windowing, remote annotation

Ethernet

10BaseT/100BaseTX, auto-switching, auto-negotiating, auto-discovery, full/half duplex, TCP/IP, UDP/IP, CIP, DHCP, IEEE 802.3U compliant

Video*

Signal Types : RGB and auto-detecting composite, S-Video, or component video

Formats: SDTV 480i (NTSC) & 576i (PAL), EDTV 480p & 576p, HDTV 720p & 1080i; RGB(VGA) up to UXGA 1600 x 1200

Color Depth: 24-bit, 16.7M colors

Features: Dual-window each scalable to full-screen, time base correction, gamma correction, line doubling, motion adaptive deinterlacing, reverse 3:2/2:2 pulldown

Audio*

Hardware Features: Built-in microphone and biamplified speakers, stereo headphone output, internal volume control and audio mixer

Audio Feedback (WAV): 8-bit PCM, mono, 8 kHz sampling rate

D-A Conversion (QM): 24-bit, 48 kHz

Amplification: Bi-amplified, mono, 5 Watts for high-frequency, 5 Watts for low-frequency

Buttons

- (4) Backlit "hard key" buttons, programmable
- (1) Backlit hard reset button, reboots the touchpanel

Connectors

QM IN 1 : (1) 8-wire RJ45 female, QuickMedia input port;

Signal Types: Dynamically configurable under system control as:

- (1) RGB (VGA) input with stereo program audio and (2) mic channels, or
- (1) Auto-detecting component (YPbPr), S-Video (Y/C), or composite video input with stereo program audio and (2) mic channels;

RGB Format: RGBHV;

RGB Input Resolution, Non-interlaced: 640 x 480 minimum to 1600 x 1200 maximum (60 Hz limit at 1600 x 1200);

Video/HDTV Formats: 480i (NTSC), 576i (PAL), 480p, 576p, 720p and 1080i;

Horizontal Frequency: 15 to 100 kHz;

Vertical Frequency: 50 to 85 Hz;

Delay Skew Compensation: 0 - 22 ns;

Connects to QM output port of a **QM-TX** or other QuickMedia device via **CRESCAT-QM** or **CRESCAT-IM** cable;

Maximum Cable Length: 450 ft (aggregate distance from QM origination)

QM-IN 2 : (1) 8-wire RJ45 female, QuickMedia input port;

Signal Types: Dynamically configurable under system control as:

- (1) RGB (VGA) input with stereo program audio and (2) mic channels, or
- (1) Auto-detecting component (YPbPr), S-Video (Y/C), or composite video input with stereo program audio and (2) mic channels;

RGB Format: RGBHV;

RGB Input Resolution, Non-interlaced: 640 x 480 minimum to 1600 x 1200 maximum (60 Hz limit at 1600 x 1200);

Video/HDTV Formats: 480i (NTSC), 576i (PAL), 480p, 576p, 720p and 1080i;

Horizontal Frequency: 15 to 100 kHz;

Vertical Frequency: 50 to 85 Hz;

Delay Skew Compensation: none;

Connects to QM output port of a **QM-TX** or other QuickMedia device via **CRESCAT-QM** or **CRESCAT-IM** cable;

Maximum Cable Length (SDTV): 450 ft for 480i and 576i (aggregate distance from QM origination);

Maximum Cable Length (EDTV/HDTV): 300 ft for 480p, 576p, 720p, 1080i, and 1080p (aggregate distance from QM origination);

Maximum Cable Length (RGB @ 60Hz): 216 ft for 640x480, 140 ft for 800x600, 84 ft for 1024x768, 70 ft for 1280x768, 30 ft for 1600x1200

(aggregate distance from QM origination using **CRESCAT-QM** or **CRESCAT-IM** cable)

TPS-15G-QM

QM OUT 1 : (1) 8-wire RJ45 female, QuickMedia output port containing RGB (same as touchscreen), WAV file audio, and internal microphone signals; RGB Format: RGBHV;

RGB Output Resolution, Non-interlaced: 1024 x 768 pixels @ 60 Hz;
Connects to QM input port of any QuickMedia device via **CRESCAT-QM** or **CRESCAT-IM** cable

HEADPHONES: (1) 3.5 mm TRS mini phone jack;

Output Power: 12mW per channel;

Minimum Impedance: 32 ohms

RS-232: (1) 6-pin RJ11 female;

Computer console, touch output, or mouse/touch input port†;

Bidirectional RS-232 up to 115.2k baud;

Hardware and software handshaking support

LAN: (1) 8-wire RJ45 with 2 LED indicators;

10BaseT/100BaseTX Ethernet port;

Green LED indicates link status;

Yellow LED indicates Ethernet activity

24VDC: (1) 2.1mm barrel DC power jack;

24V DC power input (power supply sold separately)‡

NET: (1) 4-pin 3.5mm detachable terminal block;

Cresnet Slave Port, connects to Cresnet control network

USB: (2) USB Type A female;

USB 1.1 ports for mouse or touchscreen input†

GND: (1) 6-32 screw, chassis ground lug

MEMORY EXP. : (1) Type II Compact Flash card slot for memory expansion

PC CARD A - B : (2) Type II PC Card slots (reserved for future applications)†

Power Requirements

24VDC: 3.13 Amps @ 24 Volts DC (power supply sold separately)‡

Cresnet Power Usage : 75 Watts (3.13 Amps @ 24 Volts DC)

Note: May be powered via Cresnet, 24VDC power jack‡, or **TPS-17G-QM/-L-IMC** power interface module (sold separately). Power should only be applied to the 24VDC power jack OR the NET port, not both.

Environmental

Temperature: 41° to 113°F (5° to 45°C)

Humidity: 10% to 90% RH (non-condensing)

Enclosure

Construction: High impact black/silver injection-molded case, tilt screen with adjustable tension, integral rear cover and cable strain relief in base

Screen Tilt: Adjustable 45 to 90 degrees

Dimensions

Height: 14.17 in (36.00 cm)

Width: 14.94 in (37.95 cm)

Depth: 13.75 in (34.93 cm)

Weight

15.2 lbs (6.9 kg)

* One or more **QuickMedia** devices are required to facilitate the input and output of audio, video, and RGB signals.

†Contact Crestron for a current list of compatible devices and capabilities.

‡Use **PW-2435RU** Power Supply, available only by purchasing model **TPS-17G-QM/-L-IMC** Power Interface Module.

Available Models

TPS-15G-QM: Isys G-Series 15" Touchpanel with QuickMedia

Available Accessories

CRESCAT-IM-P-DRN-SP1000: iMedia Cable, Low-skew CAT5e w/drain wire for iMedia and QuickMedia, plenum, 1000 ft spool

CRESCAT-IM-P-DRN-SP500: iMedia Cable, Low-skew CAT5e w/drain wire for iMedia and QuickMedia, plenum, 500 ft spool

CRESCAT-QM-NP-SP500: QuickMedia® Cable, Low-skew CAT5e & Cresnet, non-plenum, 500 ft spool

CRESCAT-QM-P-SP500: QuickMedia® Cable, Low-skew CAT5e & Cresnet, plenum, 500 ft spool

CRESNET-HP-NP-TL-SP1000: Cresnet® "High-Power" Control Cable, non-plenum, teal, 1000 ft spool

CRESNET-HP-NP-TL-SP500: Cresnet® "High-Power" Control Cable, non-plenum, teal, 500 ft spool

CRESNET-NP-BK-B500: Cresnet® Control Cable, non-plenum, black, 500 ft box

CRESNET-NP-OR-B500: Cresnet® Control Cable, non-plenum, orange, 500 ft box

CRESNET-NP-TL-B250: Cresnet® Control Cable, non-plenum, teal, 250 ft box

CRESNET-NP-TL-B500: Cresnet® Control Cable, non-plenum, teal, 500 ft box

CRESNET-NP-TL-SP1000: Cresnet® Control Cable, non-plenum, teal, 1000 ft spool

CRESNET-NP-TL-SP500: Cresnet® Control Cable, non-plenum, teal, 500 ft spool

CRESNET-NP-YL-B500: Cresnet® Control Cable, non-plenum, yellow, 500 ft box

CRESNET-P-BK-SP500: Cresnet® Control Cable, plenum, black, 500 ft spool

CRESNET-P-OR-SP500: Cresnet® Control Cable, plenum, orange, 500 ft spool

CRESNET-P-TL-SP1000: Cresnet® Control Cable, plenum, teal, 1000 ft spool

CRESNET-P-TL-SP500: Cresnet® Control Cable, plenum, teal, 500 ft spool

CRESNET-P-YL-SP500: Cresnet® Control Cable, plenum, yellow, 500 ft spool

QM-TX: QuickMedia Transmitter

SMK-12/15/17: Swivel Mount Kit

ST-PK: Programming Cable Kit

TPS-17G-QM/-L-IMC: Power Interface Module and Power Supply

TPS/TPMC-CBL-T3-B: Triamese Cable, 3 ft, Black

TPS/TPMC-CBL-T3-W: Triamese Cable, 3 ft, White

TPS/TPMC-CBL-T6-B: Triamese Cable, 6 ft, Black

TPS/TPMC-CBL-T6-W: Triamese Cable, 6 ft, White

TPS/TPMC-CBL-T9-B: Triamese Cable, 9 ft, Black

TPS/TPMC-CBL-T9-W: Triamese Cable, 9 ft, White

TPS-15G-QM

TPS-15G-QM in a Quickmedia system

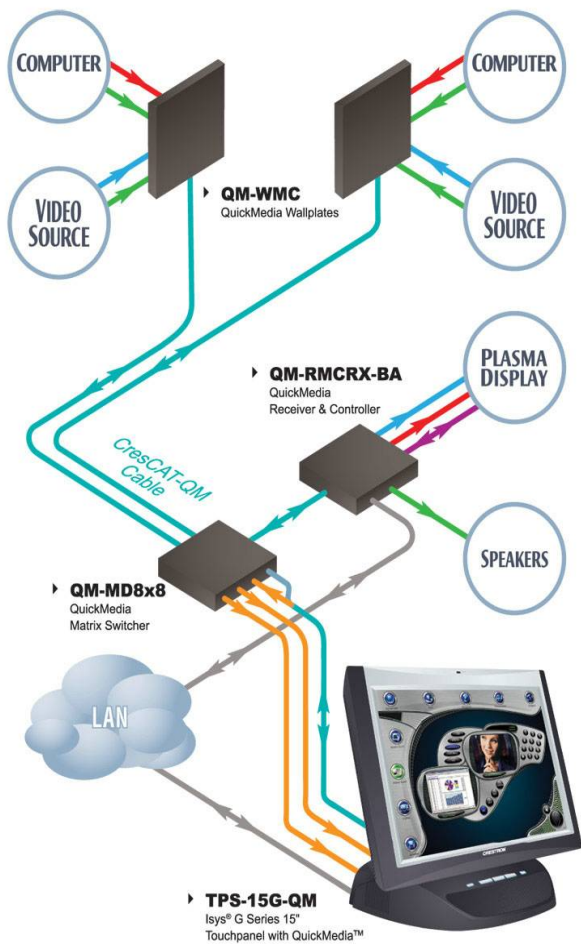

Color Key		
Control	Video	Audio
CAT5E	Cresnet	LAN
RGB	CresCAT	



TPS-15G-QM

Front

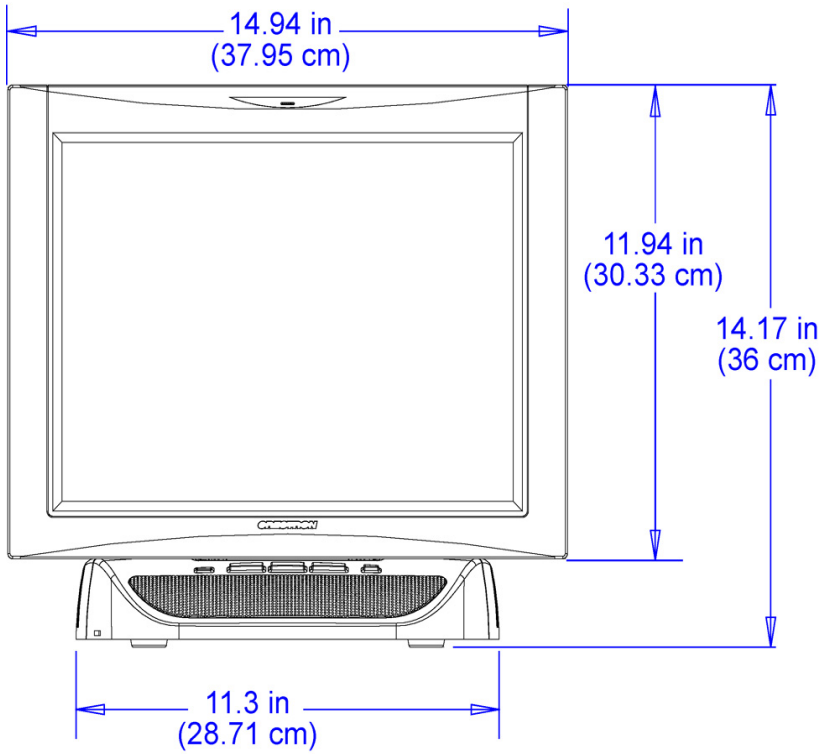

Back

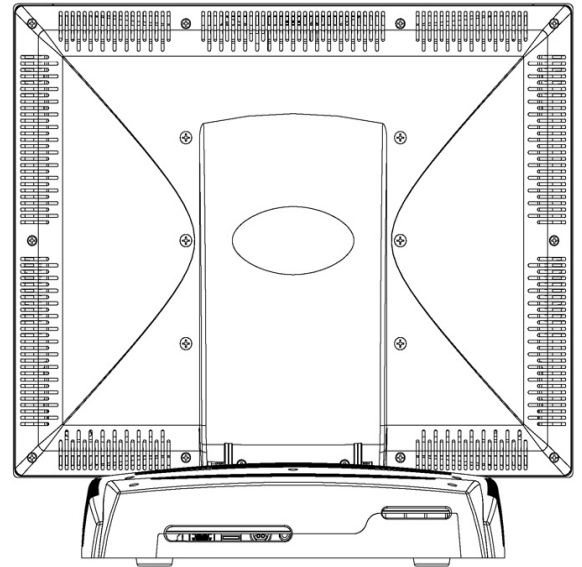

Side

